



AF809 series

Power Supply Supervisor

Features

- Low power consumption
- Low temperature coefficient
- Built-in delay circuit: 200ms
- High input voltage (up to 9V)
- Output voltage accuracy: tolerance $\pm 2\%$
- SOT23 ,SOT23-3 and SOT89 package

Applications

- Microprocessor reset circuitry
- Memory battery back-up circuits
- Power on reset circuits
- System battery life and charge voltage monitors
- Delay circuitry
- Power failure detection

General Description

The AF809 series are highly accurate, low power consumption voltage detectors, manufactured using CMOS and laser trimming technologies. A delay circuit is built-in to each detectors. Detect voltage is extremely accurate with minimal temperature drift. Both CMOS and N-ch open drain output configurations are available. Since the delay circuit is built-in, peripherals are unnecessary and high density mounting is possible.

Selection Table

Part No	Detectable Voltage	Delay Time	Tolerance	Package	marking	Package Option
AF809CXXXz	4.63V	200ms	$\pm 2\%$	SOT23 SOT23-3 SOT89	AAAA.	SOT23 and SOT23-3: Tape and Reel, 3000 SOT89: Tape and Reel, 1000
AF809CXXXz	4.38V		$\pm 2\%$		ABAA.	
AF809CXXXz	4.00V		$\pm 2\%$		CWAA.	
AF809CXXXz	3.08V		$\pm 2\%$		ACAA.	
AF809CXXXz	2.93V		$\pm 2\%$		ADAA.	
AF809CXXXz	2.63V		$\pm 2\%$		AFAA.	
AF809NXXXz	4.63V		$\pm 2\%$		BAAA.	
AF809NXXXz	4.38V		$\pm 2\%$		BBAA.	
AF809NXXXz	4.00V		$\pm 2\%$		BWAA.	
AF809NXXXz	3.08V		$\pm 2\%$		BCAA.	
AF809NXXXz	2.93V		$\pm 2\%$		BDAA.	
AF809NXXXz	2.63V		$\pm 2\%$		BFAA.	

Note: "C" or "N" is CMOS or NMOS output."XXX" stands for output voltages."z" stands for package.



AF809 series Power Supply Supervisor

Order Information

AF809①②③④⑤⑥

Designator	Symbol	Description
①	C	CMOS output
	N	NMOS output
②③④	XXX	Detect voltage
⑤	N	Package:SOT23
	M	Package:SOT23-3
	P	Package:SOT89
⑥	R	RoHS / Pb Free
	G	Halogen Free

Block Diagram

(1) CMOS output

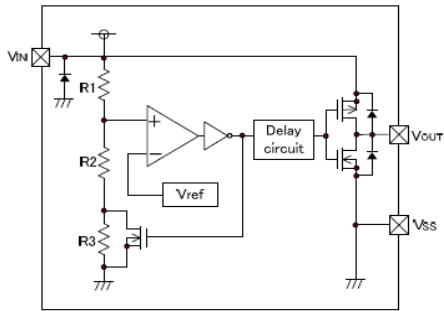

(2) N-ch open drain output

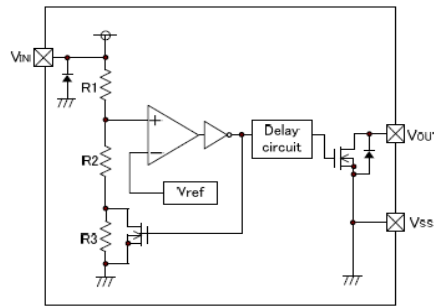

Pin Assignment

SOT23 (Top view) SOT23-3 (Top view) SOT89 (Top view)

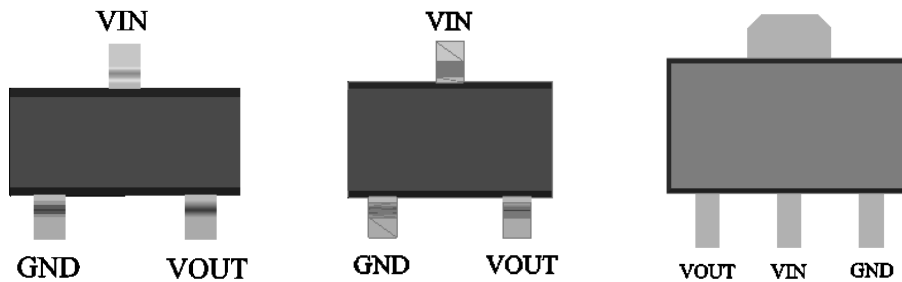

Absolute Maximum Ratings

Input Voltage	-0.3V to 10.0V	Storage Temperature	-40°C to 125°C
RESET, RESET	-0.3V to VCC + 0.3V	Operating Temperature	-40°C to 85°C
Junction Temperature(max).....	150°C	Lead temperature (soldering 10S)	260°C

Note: These are stress ratings only. Stresses exceeding the range specified under "Absolute Maximum Ratings" may cause substantial damage to the device. Functional operation of this device at other conditions beyond those listed in the specification is not implied and prolonged exposure to extreme conditions may affect device reliability.



AF809 series Power Supply Supervisor

Thermal Information

Symbol	Parameter	Package	Max.	Unit
θ_{JA}	Thermal Resistance (Junction to Ambient) (Assume no ambient airflow, no heat sink)	SOT23	260	$^{\circ}\text{C}/\text{W}$
		SOT23-3	250	$^{\circ}\text{C}/\text{W}$
		SOT89	150	$^{\circ}\text{C}/\text{W}$
P_D	Power Dissipation	SOT23	0.2	W
		SOT23-3	0.3	W
		SOT89	0.50	W

Note: P_D is measured at $T_a = 25^{\circ}\text{C}$

Electrical Characteristics

Symbol	Parameter	Test Conditions		Min.	Typ.	Max.	Unit
V_{CC}	Input Voltage (V_{CC}) Range	$T_A = 0^{\circ}\text{C}$ to 70°C $T_A = -40^{\circ}\text{C}$ to 105°C		1.1 1.2		7.5 7.5	V
I_{SS}	Supply Current	$T_A = -40^{\circ}\text{C}$ to 85°C $T_A = -40^{\circ}\text{C}$ to 85°C $T_A = 85^{\circ}\text{C}$ to 105°C $T_A = 85^{\circ}\text{C}$ to 105°C	$V_{CC} < 5.5\text{V}$, L/M/J $V_{CC} < 3.6\text{V}$, R/S/T $V_{CC} < 5.5\text{V}$, L/M/J $V_{CC} < 3.6\text{V}$, R/S/T		1.5 1	1.8 1.2 2.8 2.5	μA
V_{TH}	Reset Threshold	L devices	$T_A = 25^{\circ}\text{C}$ $T_A = -40^{\circ}\text{C}$ to 85°C $T_A = 85^{\circ}\text{C}$ to 105°C	4.56 4.50 4.40	4.63	4.70 4.75 4.86	V
		M devices	$T_A = 25^{\circ}\text{C}$ $T_A = -40^{\circ}\text{C}$ to 85°C $T_A = 85^{\circ}\text{C}$ to 105°C	4.31 4.25 4.16	4.38	4.45 4.50 4.56	
		J devices	$T_A = 25^{\circ}\text{C}$ $T_A = -40^{\circ}\text{C}$ to 85°C $T_A = 85^{\circ}\text{C}$ to 105°C	3.93 3.89 3.80	4.00	4.06 4.10 4.20	
		T devices	$T_A = 25^{\circ}\text{C}$ $T_A = -40^{\circ}\text{C}$ to 85°C $T_A = 85^{\circ}\text{C}$ to 105°C	3.04 3.00 2.92	3.08	3.11 3.15 3.23	
		S devices	$T_A = 25^{\circ}\text{C}$ $T_A = -40^{\circ}\text{C}$ to 85°C $T_A = 85^{\circ}\text{C}$ to 105°C	2.89 2.85 2.78	2.93	2.96 3.00 3.08	
		R devices	$T_A = 25^{\circ}\text{C}$ $T_A = -40^{\circ}\text{C}$ to 85°C $T_A = 85^{\circ}\text{C}$ to 105°C	2.59 2.55 2.50	2.63	2.66 2.70 2.76	



AF809 series Power Supply Supervisor

	Reset Threshold Stability		30		Ppm/ °C
	V _{CC} to Reset Delay	V _{CC} = V _{TH} to V _{TH} - 100mV	20		us
V _{OL}	Reset Active	TA = -40°C to 85°C	150	200	250
	Timeout Period	TA = 85°C to 105°C	100		

VDF(T): Setting detect voltage value

Note: The power consumption during power-start to output being stable (release operation) is 2A greater it is after that period (completion of release operation) because of delay circuit through current.

Timing Chart

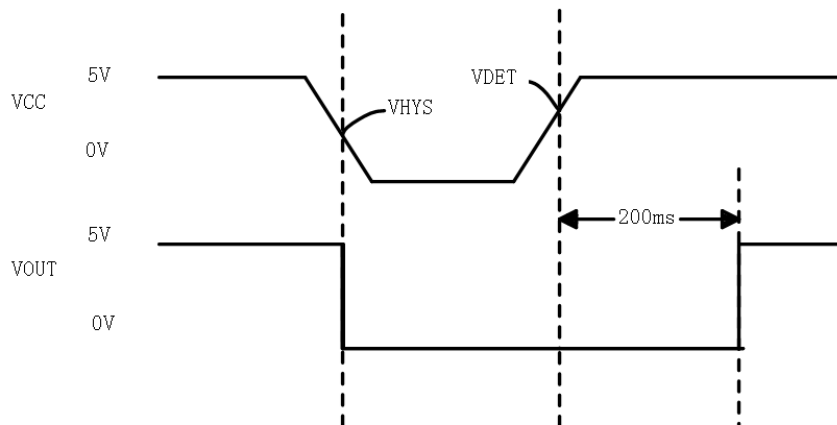

Application Circuits

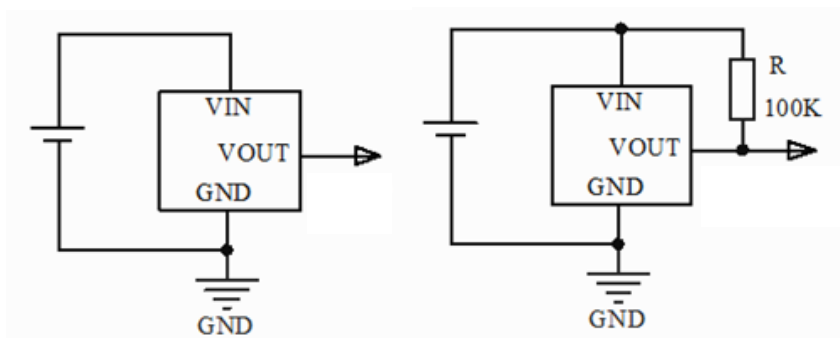

CMOS OUTPUT

NMOS OPEN DRAIN OUTPUT



AF809 series Power Supply Supervisor

Package Information 3-pin SOT23 Outline Dimensions

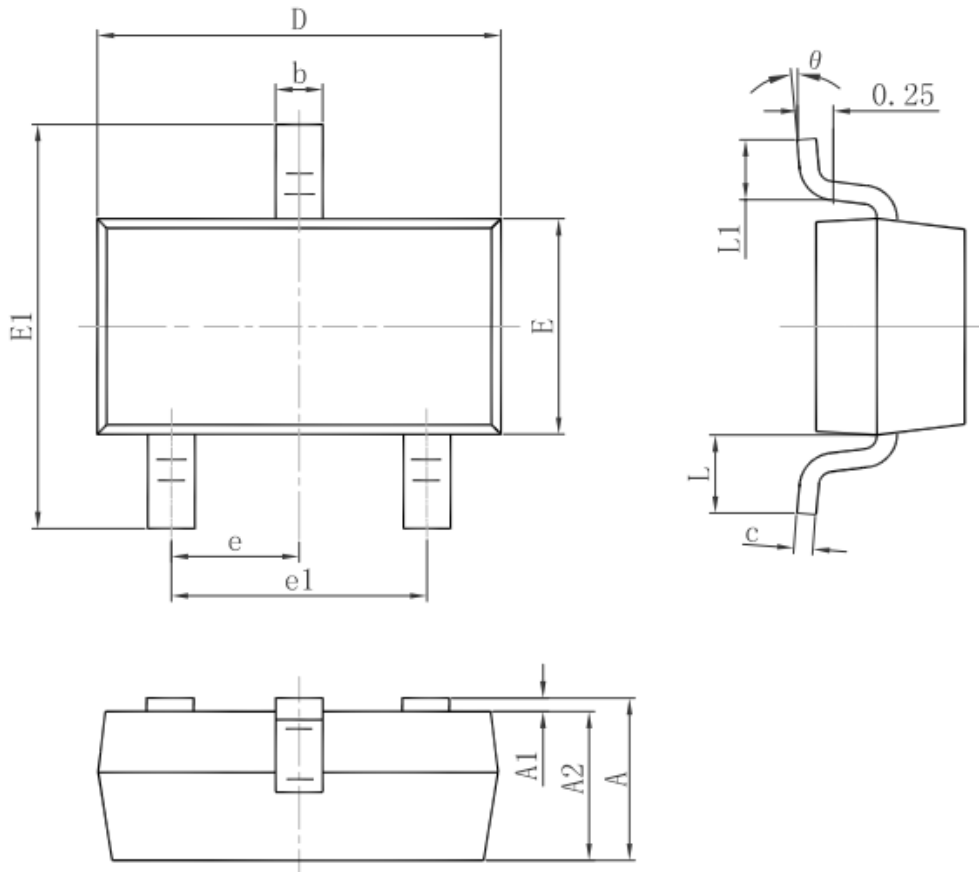

Symbol	Dimensions In Millimeters		Dimensions In Inches	
	Min.	Max.	Min.	Max.
A	0.900	1.150	0.035	0.045
A1	0.000	0.100	0.000	0.004
A2	0.900	1.050	0.035	0.041
b	0.300	0.500	0.012	0.020
c	0.080	0.150	0.003	0.006
D	2.800	3.000	0.110	0.118
E	1.200	1.400	0.047	0.055
E1	2.250	2.550	0.089	0.100
e	0.950 TYP.		0.037 TYP.	
e1	1.800	2.000	0.071	0.079
L	0.550 REF.		0.022 REF.	
L1	0.300	0.500	0.012	0.020
θ	0°	8°	0°	8°



AF809 series Power Supply Supervisor

3-pin SOT89 Outline Dimensions

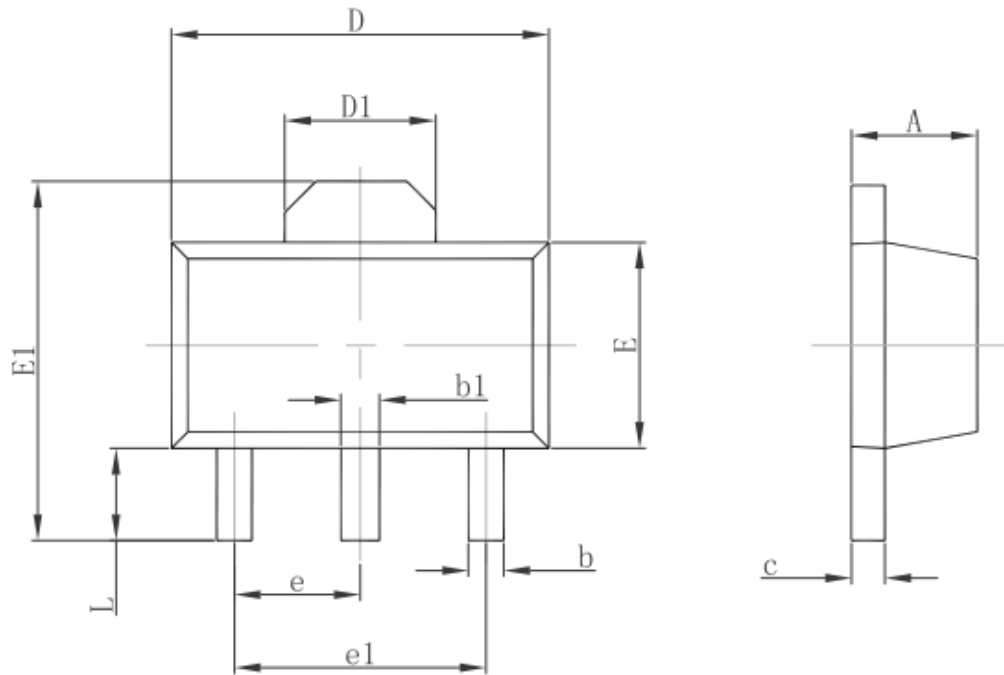

Symbol	Dimensions In Millimeters		Dimensions In Inches	
	Min.	Max.	Min.	Max.
A	1.400	1.600	0.055	0.063
b	0.320	0.520	0.013	0.020
b1	0.400	0.580	0.016	0.023
c	0.350	0.440	0.014	0.017
D	4.400	4.600	0.173	0.181
D1	1.550 REF.		0.061 REF.	
E	2.300	2.600	0.091	0.102
E1	3.940	4.250	0.155	0.167
e	1.500 TYP.		0.060 TYP.	
e1	3.000 TYP.		0.118 TYP.	
L	0.900	1.200	0.035	0.047



AF809 series Power Supply Supervisor

3-pin SOT23-3 Outline Dimensions

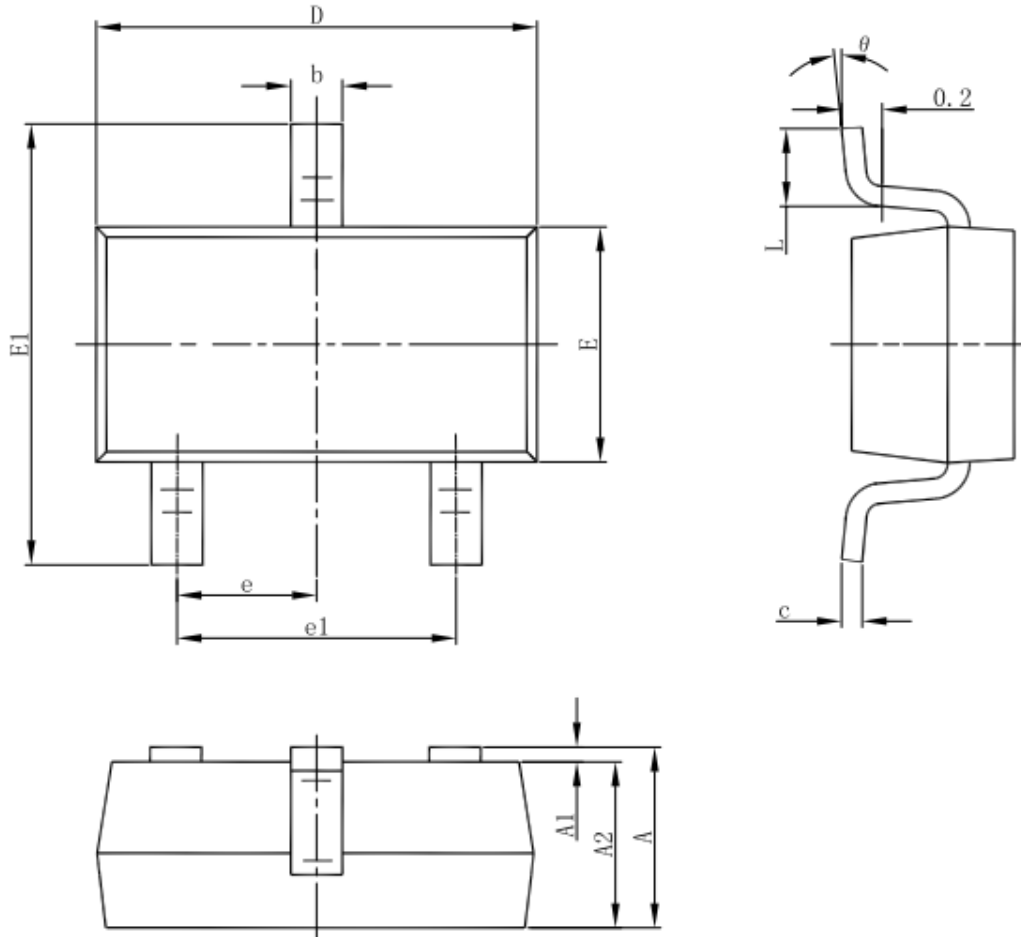

Symbol	Dimensions In Millimeters		Dimensions In Inches	
	Min	Max	Min	Max
A	1.050	1.250	0.041	0.049
A1	0.000	0.100	0.000	0.004
A2	1.050	1.150	0.041	0.045
b	0.300	0.500	0.012	0.020
c	0.100	0.200	0.004	0.008
D	2.820	3.020	0.111	0.119
E	1.500	1.700	0.059	0.067
E1	2.650	2.950	0.104	0.116
e	0.950(BSC)		0.037(BSC)	
e1	1.800	2.000	0.071	0.079
L	0.300	0.600	0.012	0.024
θ	0°	8°	0°	8°



AF809 series Power Supply Supervisor

● Taping dimension

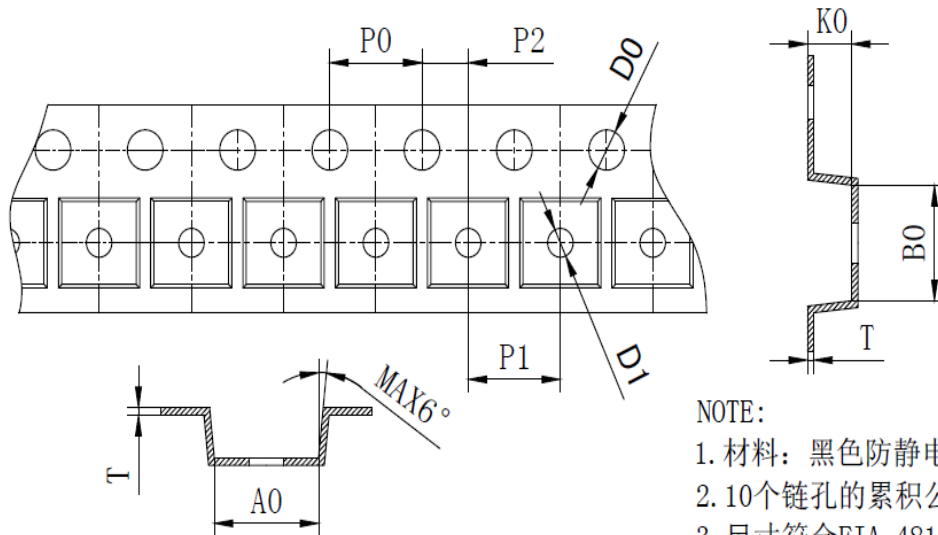

NOTE:

1. 材料：黑色防静电材料；
2. 10个链孔的累积公差不能超过±0.2；
3. 尺寸符合EIA-481-E的要求。

SYMBOL	A0	B0	K0	P0	P1	P2
SPEC	3.30±0.10	3.20±0.10	1.50±0.10	4.00±0.10	4.00±0.10	2.00±0.05
SYMBOL	T	E	F	D0	D1	W
SPEC	0.20±0.05	1.75±0.10	3.50±0.05	1.55±0.05	1.10 ^{+0.10} ₋₀	8.00 ^{+0.2} _{0.1}



AF809 series Power Supply Supervisor

8mm&12mm 7" 英寸卷盘
8mm&12mm 7" carrier tape reel

规格: 蓝色7寸*8mm

DWG NO. 2014080501

TOOLLING NO. : _____

DATE : 20140805

Tape Size	A Max	B Min	C	D Min	N Min	W1	W2 Max	W3
8 mm	178	1.5	13.0±0.20	20.2	50	8.4 ^{+1.5} _{-0.0}	14.4	7.9Min 10.9Max
12 mm						12.4 ^{+2.0} _{-0.0}		7.9Min 10.9Max

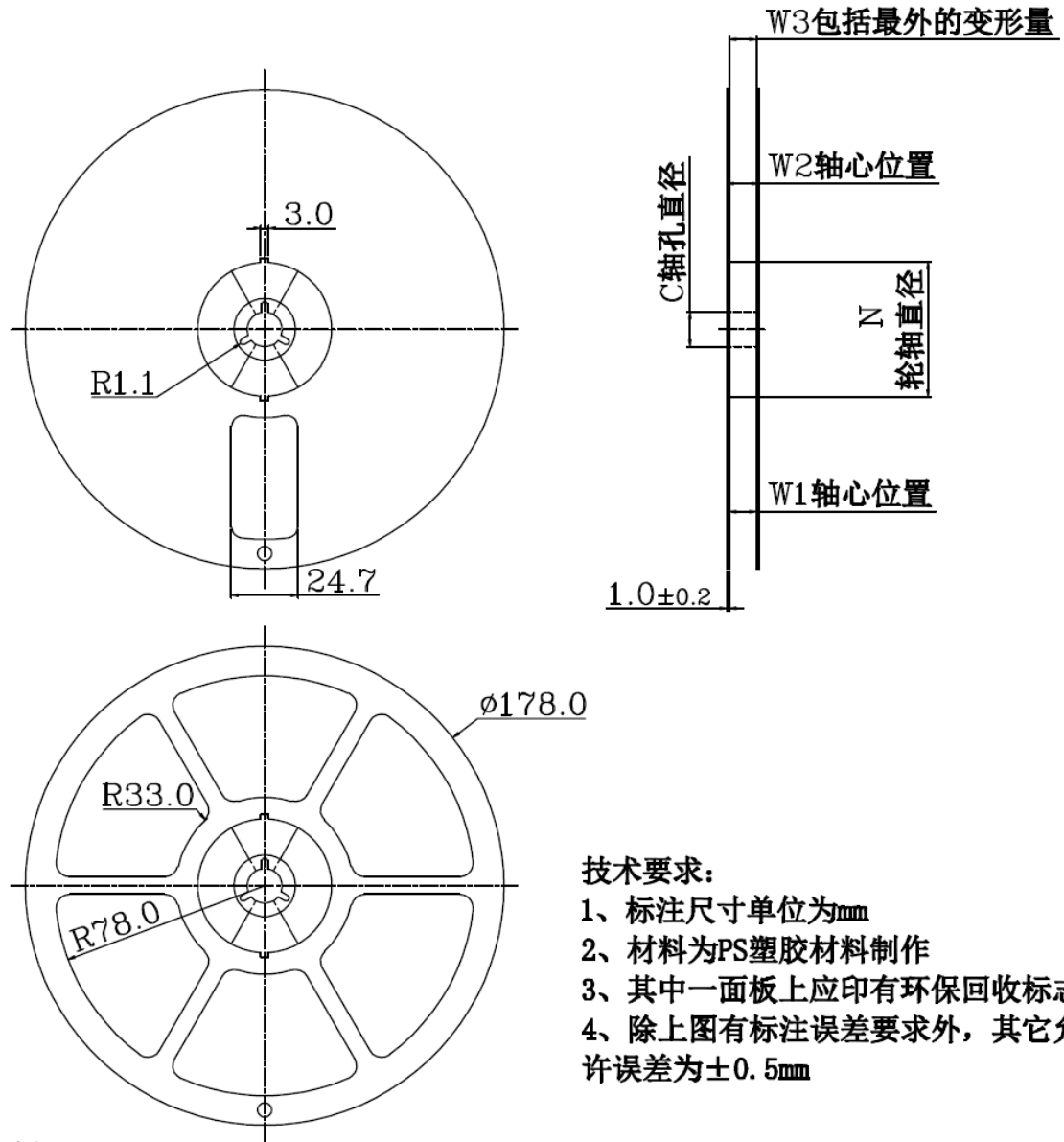

比例: 1:6



AF809 series

Power Supply Supervisor

DISCLAIMER

SSCSEMI RESERVES THE RIGHT TO MAKE CHANGES WITHOUT FURTHER NOTICE TO ANY PRODUCTS HEREIN TO IMPROVE RELIABILITY, FUNCTION OR DESIGN. SSCSEMI DOES NOT ASSUME ANY LIABILITY ARISING OUT OF THE APPLICATION OR USE OF ANY PRODUCT OR CIRCUIT DESCRIBED HEREIN; NEITHER DOES IT CONVEY ANY LICENCE UNDER ITS PATENT RIGHTS, NOR THE RIGHTS OF OTHERS.

THE GRAPHS PROVIDED IN THIS DOCUMENT ARE A STATISTICAL SUMMARY BASED ON A LIMITED NUMBER OF SAMPLES AND ARE PROVIDED FOR INFORMATIONAL PURPOSE ONLY. THE PERFORMANCE CHARACTERISTICS LISTED IN THEM ARE NOT TESTED OR GUARANTEED. IN SOME GRAPHS, THE DATA PRESENTED MAY BE OUTSIDE THE SPECIFIED OPERATING RANGE (E.G. OUTSIDE SPECIFIED POWER SUPPLY RANGE) AND THEREFORE OUTSIDE THE WARRANTED RANGE.